



Leica VT1000 A

Vibratome



Operating Manual

Leica VT1000 A

V1.1 English - 01/2010

Always keep this manual with the instrument.

Read carefully before working with the instrument.

Leica
MICROSYSTEMS

NOTE

The information, numerical data, notes and value judgments contained in this manual represent the current state of scientific knowledge and state-of-the-art technology as we understand it following thorough investigation in this field.

We are under no obligation to update the present manual periodically and on an ongoing basis according to the latest technical developments, nor to provide our customers with additional copies, updates etc. of this manual.

To the extent permitted in accordance with the national legal system as applicable in each individual case, we shall not be held liable for erroneous statements, drawings, technical illustrations etc. contained in this manual. In particular, no liability whatsoever shall be accepted for any financial loss or consequential damage caused by or related to compliance with statements, instructions or other information in this manual.

Statements, drawings, illustrations and other information regarding the contents or technical details of the present Operating Manual are not to be considered warranted characteristics of our products.

These are determined only by the contract provisions agreed between ourselves and our customers.

Leica reserves the right to change technical specifications as well as manufacturing processes without prior notice. Only in this way is it possible to continuously improve the technology and manufacturing techniques used in our products.

This document is protected under copyright laws. All copyrights to this documentation are held by Leica Biosystems Richmond LLC.

Any reproduction of text and illustrations (or of any parts thereof) by means of print, photocopy, microfiche, web cam or other methods—including any electronic systems and media—requires express prior permission in writing by Leica Biosystems Richmond LLC.

For the instrument serial number and year of manufacture, please refer to the nameplate at the rear side of the instrument.

© Leica Biosystems Richmond LLC

Published by:

Leica Biosystems Richmond, LLC

5205 Route 12 P.O. Box

528 Richmond, IL 60071

United States of Amerika

Telefon: +1 800 225-3035

Fax: +1 815 678-2216

Internet: www.leica-microsystems.com

Contents

1.	Important Notes	5
2.	Safety.....	6
2.1	Safety notes.....	6
2.2	Warnings.....	6
3.	Instrument Components and Specifications	9
3.1	Overview — instrument components	9
3.2	Technical data	10
4.	Setup the Instrument.....	12
4.1	Standard delivery	11
4.2	Installation site requirements.....	12
4.3	Unpacking and setting up the instrument	13
4.4	Connection to power supply system	14
4.4.1	Checking the performance requirements	14
4.4.2	Connecting to the power supply	15
4.5	Connecting the foot switch.....	16
4.6	Assembling the "deluxe specimen tray".....	17
4.7	Assembling the specimen clamp.....	19
4.7.1	Inserting the round specimen tray	20
4.7.2	Assembling the directional specimen holder fixture.....	21
4.8	Assembling the magnifier	22
5.	Operation.....	23
5.1	Operating elements and their functions	23
5.1.1	The control panel.....	23
5.1.2	The operating elements.....	23
5.2	Adjustment options on the instrument.....	28
5.2.1	Adjusting the blade presentation angle.....	28
5.2.2	Adjusting the specimen and blade	29
5.2.3	Adjustable sectioning window.....	31
5.2.4	Adjusting the specimen height.....	33
5.3	Sectioning.....	34
5.3.1	General instructions.....	36
5.3.2	Inserting the specimens.....	37
5.3.3	Selecting and inserting the blade.....	39
5.4	Specimen preparation	41
5.5	Preparing the specimen bath	42
5.6	Conventional sectioning.....	43
5.7	Removing the sections	44
6.	Cleaning and Maintenance	45
6.1	Cleaning the instrument	45
6.2	Maintenance instructions.....	47
6.3	Replacing components.....	48
6.3.1	Fuse.....	48
6.3.2	LED Light	48
7.	Optional Accessories	49
7.1	Ordering information	49
7.2	Accessories.....	50
8.	Warranty and Service	55

Symbols in the text and their meanings



Dangers, warnings and cautions appear in a gray box and are marked by a warning triangle. ⚠



Notes, i.e. important information for the user, are highlighted in gray and marked by the **i** symbol.

(5)
(Fig.3)

Numbers in parentheses refer to item numbers in illustrations or to the illustrations themselves.

Qualification of personnel

- The Leica VT1000 A may be operated by trained laboratory personnel only.
- All laboratory personnel designated to operate the Leica instrument must read this Operating Manual carefully and must be familiar with all technical features of the instrument before attempting to operate it.

Intended use

The Leica VT1000 A is used for sectioning in the fields of medicine, biology and industry, and is especially designed for sectioning fixed or un-fixed fresh tissue in a buffer solution.

The instrument must be installed according to the directions in this Operating Manual.

Any other use of the instrument is considered improper!



Instrument Type

All information contained in this Operating Manual applies solely to the instrument type listed on the cover page.

A nameplate indicating the instrument serial number is attached to the rear side of the instrument.

For all inquiries please specify

Instrument Type

Serial Number

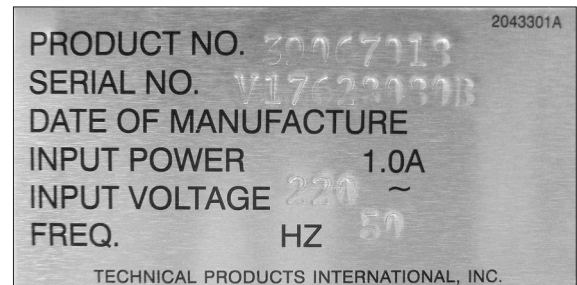

Fig. 1

2. Safety



The safety and caution notes in this chapter must be observed at all times. Be sure to read these notes even if you are already familiar with the operation and use of other Leica products.

2.1 Safety notes

This Operating Manual contains important instructions and information regarding the operational safety and maintenance of the instrument.

The Operating Manual is an important part of the product, and must be read carefully prior to startup and use and must always be kept near the instrument.

The safety precautions listed below are intended to prevent injuries of the operating personnel, damage of the instrument or impairment of the instrument's performance.

This instrument has been built and inspected in accordance with the safety regulations for electrical measuring, control, regulating and laboratory devices.

To maintain this condition and ensure safe operation, the user must observe all notes and warnings contained in this Operating Manual.



If additional requirements on accident prevention and environmental protection exceeding the scope of this Operating Manual are imposed by laws/regulations of the country of operation, this Operating Manual must be supplemented by appropriate instructions to ensure compliance with such requirements.



For current information on applicable standards, please refer to the instrument's CE declaration and visit: <http://www.leica-microsystems.com>



The protective devices located on the instrument and the accessories must not be removed or modified. The instrument must only be opened and repaired by service technicians authorized by Leica.

2.2 Warnings

The safety devices installed in this instrument by the manufacturer only constitute the basis for accident prevention. Operating the instrument safely is, above all, the responsibility of the owner, as well as the designated personnel who operate, service or clean the instrument.

To ensure trouble-free operation of the instrument, make sure to comply with the following instructions and warnings.

Warnings – Markings on the instrument itself



- Warning labels on the instrument marked with a warning triangle indicate that the correct operating instructions (as defined in this Operating Manual) must be followed when operating or replacing the item marked. Failure to adhere to these instructions may result in an accident, personal injury, damage to the instrument or accessory equipment.
- Observe the warning messages on the rear side of the instrument (Fig. 2). Only the components described in the section on "Replacing components" may be replaced by the operator.

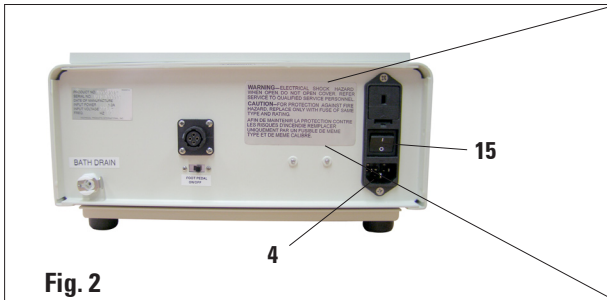

Fig. 2

WARNING—ELECTRICAL SHOCK HAZARD WHEN OPEN. DO NOT OPEN COVER. REFER SERVICE TO QUALIFIED SERVICE PERSONNEL.

CAUTION—FOR PROTECTION AGAINST FIRE HAZARD, REPLACE ONLY WITH FUSE OF SAME TYPE AND RATING.

AFIN DE MAINTENIR LA PROTECTION CONTRE LES RISQUES D'INCENDIE REMPLACER UNIQUEMENT PAR UN FUSIBLE DE MEME TYPE ET DE MEME CALIBRE.

Warnings – Transport and installation



- Once unpacked, the instrument may be transported only in an upright position.
- Never lift or transport the instrument by holding it by the blade holder or setting wheel for the section thickness.
- The instrument must be set up so that the main power switch on the left rear side of the instrument (item 14 in Fig. 2) is easily accessible at any time.

Warnings – Maintenance and cleaning



- The instrument may be opened by authorized service personnel only.
- Always disconnect the power plug before opening the instrument!
- Turn the instrument off using the power switch and disconnect the power plug before replacing the fuses. The use of fuses other than those provided is not permitted.
- Before each cleaning, remove the disposable blade or knife!
- Do not use any solvents containing acetone or xylene for cleaning! Ensure that liquids do not enter the interior of the instrument during cleaning.
- Do not clean the magnifier using cleaners that contain solvents, as the lens is made of acrylic.
- When using detergents, please comply with the safety precautions of the manufacturer and the laboratory regulations!

2. Safety

Warnings – Operating the instrument



- Take care when handling disposable blades and sapphire blades. The cutting edge is extremely sharp and can cause serious injuries!
Always wear work safety shoes and safety gloves!
- Always clamp the specimen block BEFORE clamping the blade/knife.
- If making adjustments or configuring settings in the specimen area, take the blade out of the holder in order to prevent cutting injuries from accidental contact with the blade.
- Caution! Risk of infection when working with fresh tissue or with material where an infection cannot be excluded!
- There is a fire hazard from an uncovered magnifier! Cover or remove the magnifier when the instrument is unsupervised.
- The cyanoacrylate adhesive in the accessories package included for the tissue sample adheres very quickly to human skin. Avoid contact with fingers when using the adhesive.

Proper handling



- Always be exceptionally careful when handling the blades or knife! Always make sure to handle a blade in a way that cannot cause you injury. If possible, grasp the blade using a pincers or hold it by its blunt ends only.
- Do not leave open blades lying around after removal. When disposing of used blades, apply common "Scotch" tape over the cutting edge or wrap the entire blade with paper.
- All appropriate safety precautions must be met to avoid the risk of infection!
- Wearing safety gloves, a mask and safety goggles—in accordance with the 'Working with Substances that Pose a Health Risk' guidelines—is absolutely mandatory.
- Caution! Risk of infection when working with fresh tissue or with material where an infection cannot be excluded!
- If, despite this, you come into direct contact with the cyanoacrylate adhesive provided, first allow the adhesive to air dry, then wipe it off with a towel soaked in acetone. When unintentional bonding of skin occurs, separate by a "peeling" (rather than pulling) action after applying acetone to the bond area.

3. Instrument Components and Specifications

3.1 Overview — instrument components



Fig. 3

3. Instrument Components and Specifications

3.2 Technical data

General

Approvals:	The instrument-specific approval marks are located on the identification label.
Operating temperature range:	+10 °C to +35 °C
Relative humidity:	max. 80% non-condensing
Operating temperature range during storage:	+ 5 °C to +55 °C
Storage humidity:	< 80 %

Microtome

Max. section travel length:	0 - 40 mm
Sectioning Speed :	0 - 2.0 mm/s continuously adjustable
Cutting head retraction:	c 5-7 mm/s non-adjustable
Blade amplitude:	0 - 3mm, +/- 1.5mm continuously adjustable
Total specimen stroke:	15 mm
Maximum specimen size:	33 x 40 mm
Total angle adjustment:	0° to 50° continuously adjustable
Tilt, specimen holder:	-5° - +5° in one axis

Electrical data



The instrument is supplied for operation with alternating current in two voltage variants and for two different frequencies (50 Hz and 60 Hz). For the corresponding product number, refer to the table on page 14.

Voltage:	110V AC +/- 15 %	220 V AC +/- 15 %
Max. power consumption:	1 A	0.5 A
Frequency:	50 Hz or 60 Hz (for both voltage variants)	

Dimensions and weights

Width:	280 mm
Depth:	460 mm
Height:	310 mm
Weight (without accessories):	15.5 kg

4.1 Standard delivery

The standard equipment of the Leica VT1000 A is available in 3 variants and includes the following parts:

1. STARTER PACKAGE

1	Specimen Tray (includes V-block adapter).....	39053744
1	Specimen Blocks, (3 blocks).....	39053747
2	Specimen Adhesive.....	39053986
2	Feather Blades, (20 blades).....	39053234
1	Instrument Cover	39053746
1	Blade Angle Indicator	392043401
1	2x Magnifier.....	392000200MAGREPL
1	Power Cord (110V)*	392000101
1	Plug Connector, Quick Connect (bath drain)	393104023
2	Replacement Fuse	392000109
1	5/32", Short Arm Hex Key	3997000002
1	Manual and DVD	3996000107

2. PROFESSIONAL PACKAGE

1	Deluxe Specimen Bath	39053745
1	Rotating Stage Assembly	39053760
1	Specimen Blocks, (3 blocks).....	39053747
1	Foot Pedal	39053300
1	Sapphire Knife.....	39053237
3	Specimen Adhesive.....	39053986
3	Feather Blades (30 blades).....	39053234
1	Instrument Cover	39053746
1	Blade Angle Indicator	392043401
1	2x Magnifier.....	392000200MAGREPL
1	Power cable (110V)*	392000101
1	Plug Connector, Quick Connect (bath drain)	393104023
2	Replacement Fuse	392000109
1	5/32", Short Arm Hex Key	3997000002
1	Manual and DVD	3996000107

4. Setup the Instrument

3. PROFESSIONAL GOLD PACKAGE

1	Rotating Stage Assembly	39053760
1	Foot Pedal	39053300
1	Sapphire Knife	39053237
4	Specimen Adhesive	39053986
5	50 Feather Blades	39053234
1	Instrument Cover	39053746
1	Blade Angle Indicator	392043401
1	2x Magnifier	392000200MAGREPL
1	Power Cord (110V) *	392000101
1	Plug Connector, Quick Connect (bath drain)	393104023
2	Replacement Fuse	392000109
1	5/32", Short Arm Hex Key	3997000002
1	Manual and DVD	3996000107

* only one cord included; determined at time of order

1	Power Cord (220V)	392130701
1	Power Cord (AU)	392000122
1	Power Cord (UK)	392000120



The accessories ordered are included in a separate box. Carefully check the delivery against the packing list and the delivery note. Should you find any discrepancies, please contact your Leica sales office without delay.

4.2 Installation site requirements

- Stable, vibration-free laboratory bench with horizontal, even stage plate; practically vibration-free floor.
- No other instruments nearby which might cause vibrations.
- Room temperature consistently between + 10 °C and + 35 °C.
- The instrument is suitable for operation in enclosed rooms only.

4.3 Unpacking and setting up the instrument



- First check the shipment for external damages upon arrival.
- If it is evident that the shipment was damaged during transport, please make a claim to the carrier immediately.
- Ensure that the instrument is standing on a work surface that is as free of vibrations as possible.
The instrument must be set up the instrument so that the left rear side of the instrument (item 15 in Fig. 7) is easily accessible at any time.

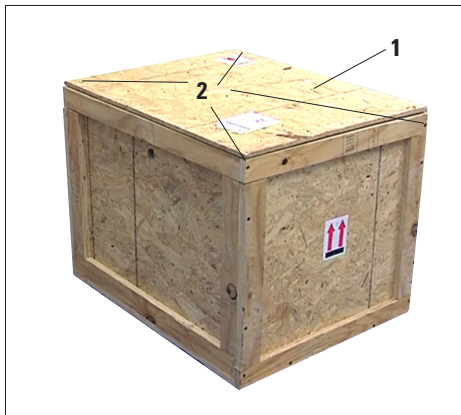

Fig. 4

1. Remove the lid (1) of the transport crate by unscrewing the 4 Phillips head screws (2).
2. Take out the accessory box (3) and remove the white packing material (5).
3. Remove the other accessory cartons.
4. To lift the instrument from the box, hold it on the left and right of the housing (Fig. 6), lift it out of the foam cushion of the package and place it on a stable lab table.



Never lift the instrument by holding it by its blade holder (6), the setting wheel (7) for the section thickness or adjustment knobs (8) for section cutting window.

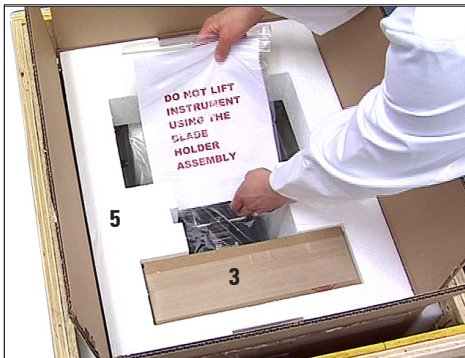

Fig. 5

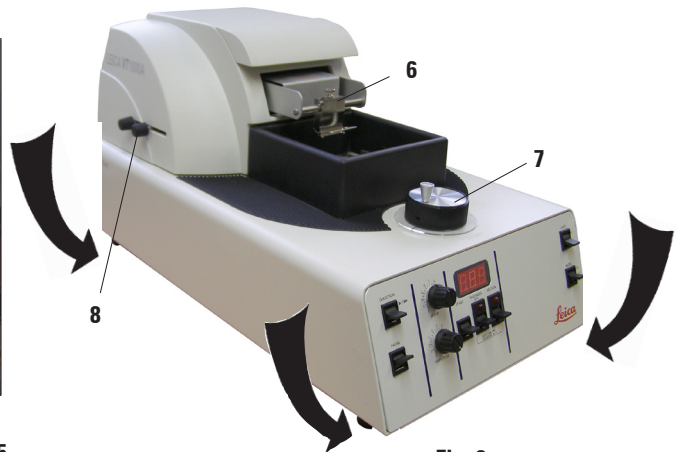

Fig. 6

4. Setup the Instrument

4.4 Connection to power supply system

4.4.1 Checking the performance requirements

The Vibratome VT1000 A is available in different versions for operation with different supply voltage.

Before connecting the instrument to the power supply, check to make sure that the product number (39 072XXX-X) and the marking for the input voltage on the rear side of the instrument match in order to ensure that the correct version for the supply voltage available at the location has been delivered.

For the assignment of the product number to the respective version, refer to the following table.

Product number	Instrument version	
39072018	Leica VT1000 A Starter	110V, 60Hz
39072018-1	LEICA VT1000 A Starter	110V, 50Hz
39072018-2	LEICA VT1000 A Starter,	220V, 50Hz
39072018-3	LEICA VT1000 A Starter	220V, 60Hz
39072020	LEICA VT1000 A Professional	110V, 60Hz
39072020-1	LEICA VT1000 A Professional	110V, 50Hz
39072020-2	LEICA VT1000 A Professional	220V, 50Hz
39072020-3	LEICA VT1000 A Professional	220V, 60Hz
39072022	LEICA VT1000 A Pro Gold	110V, 60Hz
39072022-1	LEICA VT1000 A Pro Gold	110V, 50Hz
39072022-2	LEICA VT1000 A Pro Gold	220V, 50Hz
39072022-3	LEICA VT1000 A Pro Gold	220V, 60Hz

110 V instruments have a max. amperage of 1.0A

220 V instruments have a max. amperage of 0.5A



The product number and all corresponding connection values are located on the nameplate on the rear side of the instrument. See Fig. 1, page 5

4.4.2 Connecting to the power supply

All electrical connections are on the left rear side of the instrument.



Fig. 7



The Leica VT1000A **MUST** be connected to a grounded power socket. The instrument is supplied with a power cable that is suitable for the local power supply (socket). Only this cable may be used to operate the instrument!
Do not use an extension cable!

Connecting to power supply

- Make sure that the Vibratome is switched off:
The main switch (15) on the rear side must be in the "0"= OFF position.
- Plug the power cable provided into the input socket (16) of the power supply on the instrument, then into a socket.



Severe damage may occur if the instrument is connected to a power supply voltage other than that to which it was originally set.
The power supply voltage for the instrument is factory preset and **CAN-NOT** be altered by the user.

4. Setup the Instrument

4.5 Connecting the foot switch

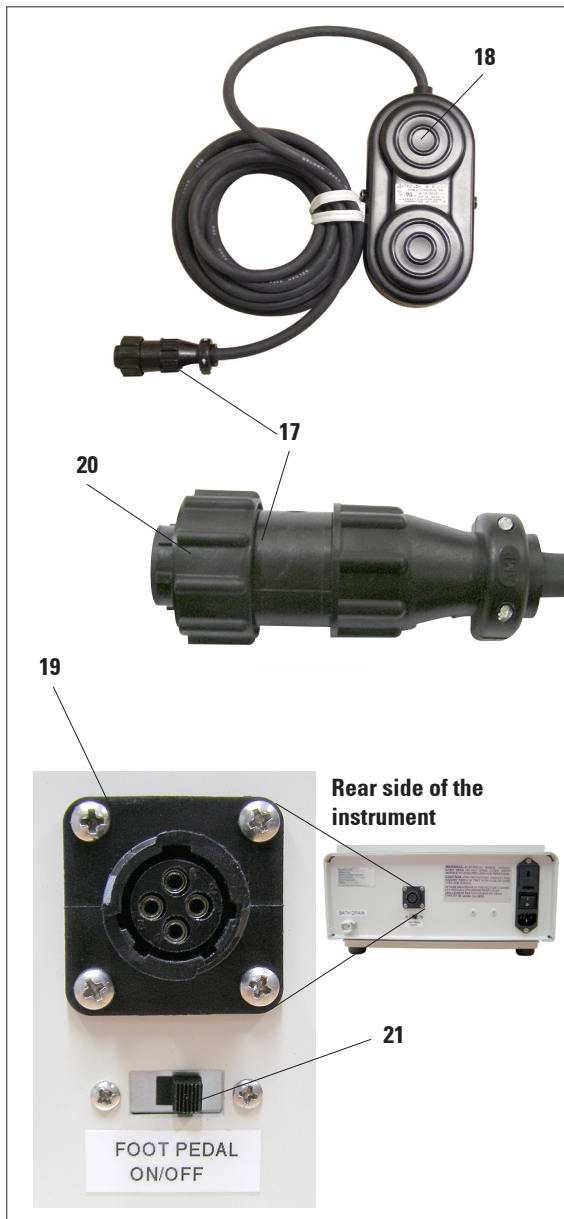

Fig. 8

The standard scope of delivery of the "Professional" and "Professional Gold" instrument versions include a foot switch (18, Fig. 8) that can be connected to the rear side of the instrument. In **SINGLE** and **AUTO** modes, the sectioning process can be started and stopped with the foot switch instead of the **DIRECTION** switch.

To connect the foot switch, follow these steps:

- Route the cable of the foot switch so that the switch on the floor can be reached easily with one foot.
- Insert the plug (17) of the foot switch into the socket (19) provided on the rear side of the instrument. This is possible in one position only; it is not possible to connect it the wrong way.
- Then screw the plug and the retaining ring (20) securely onto the thread of the socket (19).
- Before the foot switch can be used, the small switch (21) must be moved into the "ON" position, (Fig. 13).



If the foot pedal switch in the "ON" position, the movement of the blade can not be initiated by the "DIRECTION" switch.

4.6 Assembling the "deluxe specimen tray"

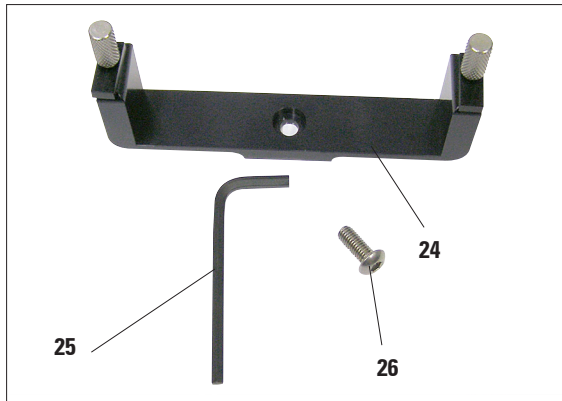

Fig. 9

- Fasten the u-frame bracket (24, Fig. 9) for the deluxe specimen bath in the main specimen bath with the corresponding countersunk hexagon screw (26) on the round specimen stage (27).

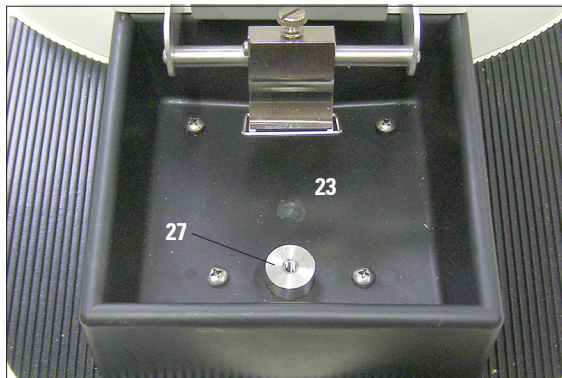

Fig. 10

The deluxe specimen bath (22, Fig. 11) is assembled inside the standard black specimen bath (23, Fig. 10). It enables separation of buffer solution and ice preventing dilution of the buffer while sectioning.

The deluxe specimen bath can be sterilized and has round specimen discs on which the specimens can be fastened very easily (Fig. 11, page 17)

The surface of the deluxe specimen bath and the specimen disks (32) both have an angle scale so that a repeatable position of the specimens relative to the blade is possible.

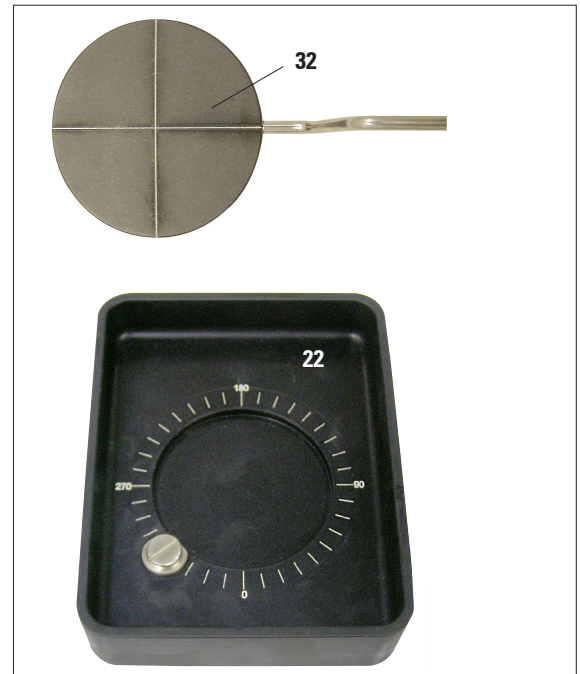

Fig. 11

4. Setup the Instrument

Assembly of the "deluxe specimen tray" (continued)

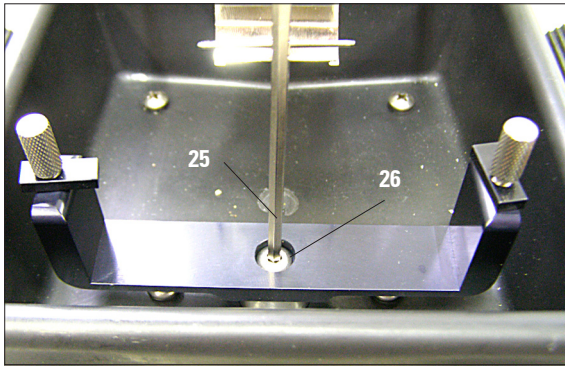

Fig. 12

Enlarged detail:
Knurled screw
and clamping
piece for fasten-
ing the deluxe
specimen tray in
the fixture.

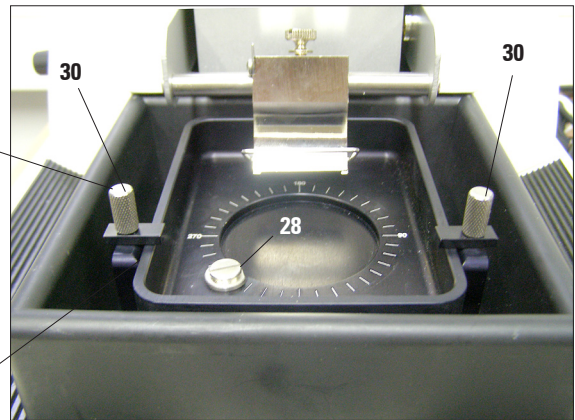
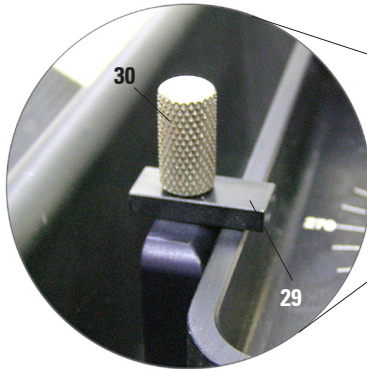

Fig. 13

- Insert the deluxe specimen tray into the installed u-frame bracket so that the slotted cam screw (28) for fastening the specimen disks is at the front left (Fig. 13).
- Then screw the specimen bath securely in place using the clamping pieces (29) and knurled screws (30) on both sides of the u-frame bracket.
- Insert the specimen disc (32) on the surface provided and clamp it in place by tightening the slotted cam screw with a screw driver (28) (Fig. 14).

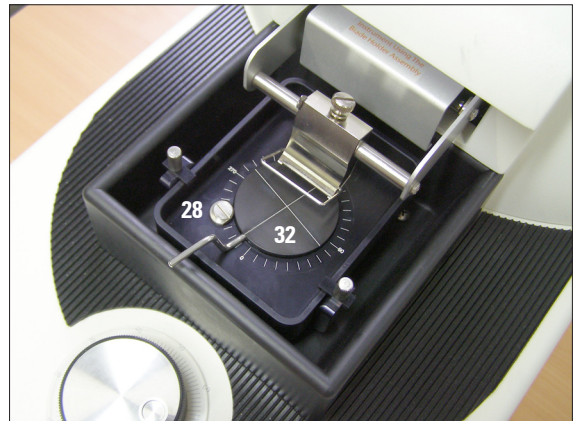

Fig. 14

4.7 Assembling the specimen vice assembly



Always remove the blade **BEFORE** installing or removing accessories!

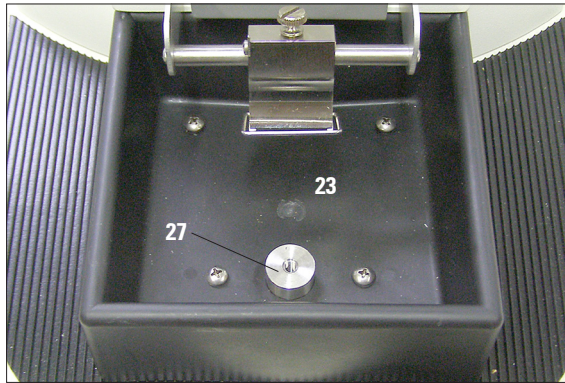

Fig. 15

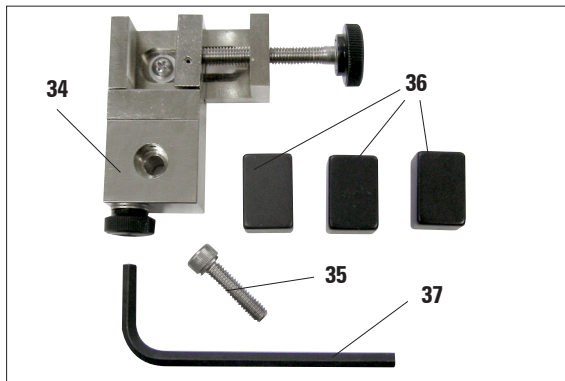

Fig. 16

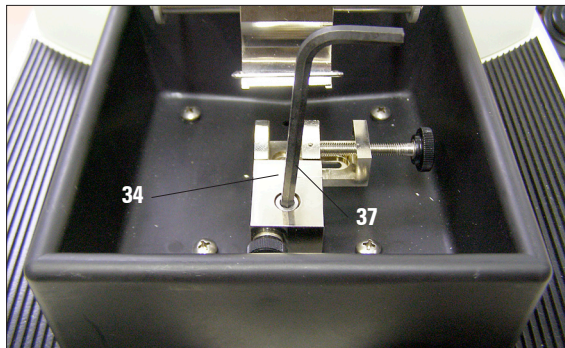

Fig. 17

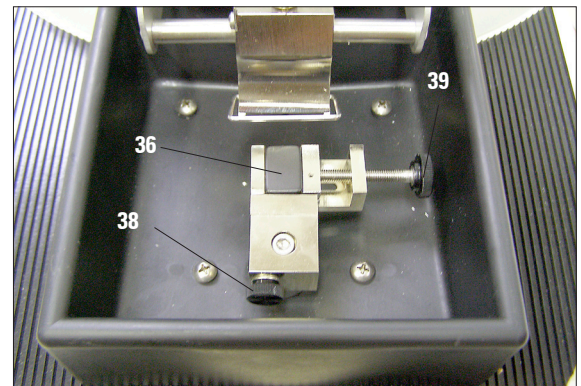

Fig. 18

- The specimen vice assembly (34, Fig. 16) is assembled inside the main specimen bath (23, Fig. 15).
- Insert the cheese head screw (35) into the bore of the specimen stage (27) and tighten it using a size 5 Allen key (37, included in the scope of delivery).
- When tightening, ensure that the fixture (34) is parallel to the front edge of the Vibratome tray (Fig. 17).
- Insert the specimen block (36) into the tension clamp and clamp it into place using the knurled screw (39) (Fig. 18).
- The specimen to be sectioned is affixed to the specimen block using the cyanoacrylate adhesive provided.
- The anterior knurled screw, allows for orientation of the specimen vice assembly, +/- 8 degrees. To change orientation, loosen the screw and press on either side of the tension clamp. (refer also to Fig. 22).

4. Setup the Instrument

4.7.1 Inserting the round specimen tray



Fig. 19

The round specimen tray (45) can be installed in place of the specimen block. It enables easy separation of buffer solution and ice that can accumulate in the main specimen bath.



Always remove the blade BEFORE installing or removing accessories!

To insert it, follow these steps:

- First, insert the V-block adapter (46) into the tensioning clamp (46) as shown in Fig. 20.
- Position the lower post at the bottom of the round specimen tray into the V-block adapter (46) so that it can be clamped into place using the knurled screw (37) (Fig. 21).
- Hold the specimen tray horizontally and clamp it into place using the knurled screw (Fig. 22).

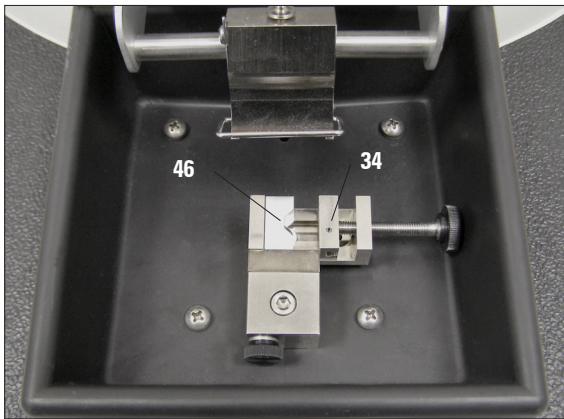

Fig. 20

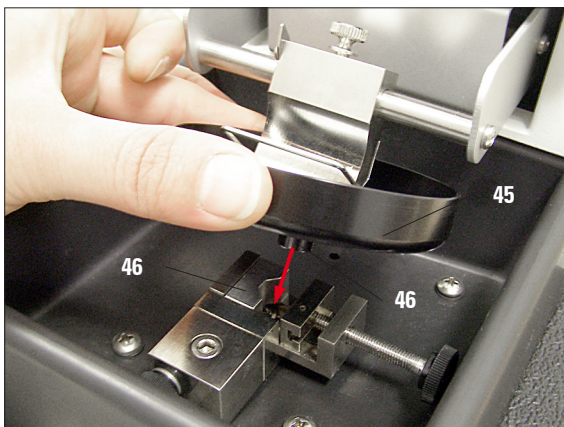

Fig. 21

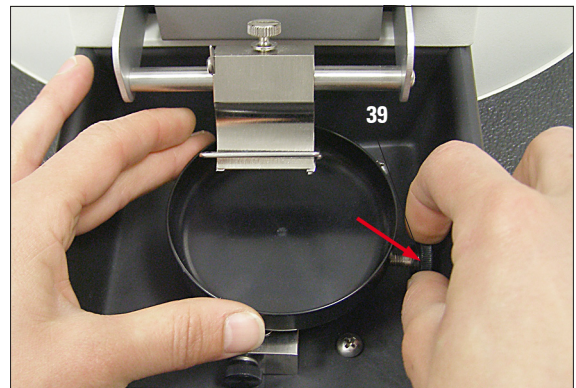

Fig. 22

4.7.2 Assembling the rotating stage assembly

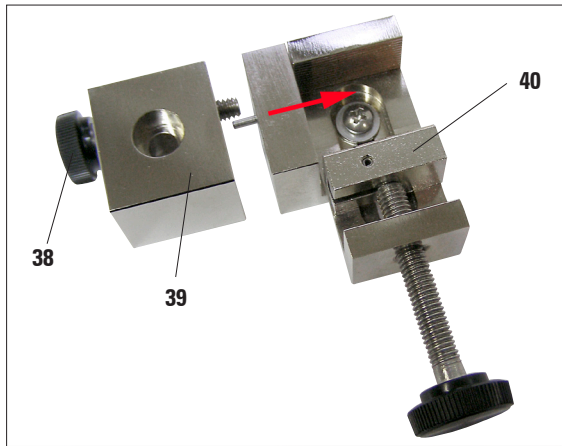

Fig. 23

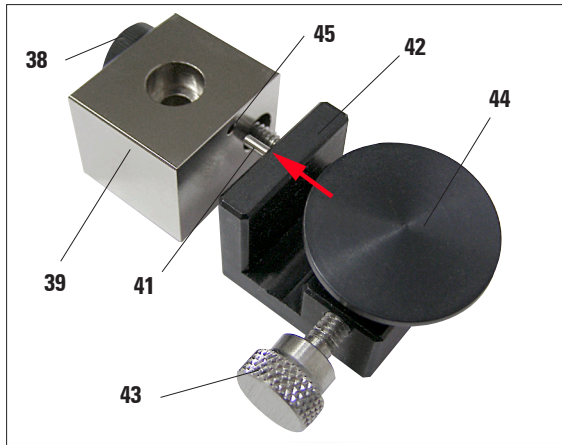

Fig. 24

- The specimen to be sectioned (44) is glued to the round specimen plate using the cyanoacrylate adhesive provided.
- To orient the specimen, slightly loosen the knurled screw (43) on the right side, adjust to the desired position and retighten the screw.

The rotating stage assembly allows for simple position correction of the specimen surface when the specimen is glued in place.

- To do so, first remove the specimen vice assembly (34, Fig. 16) by following the reverse order of steps as described in Chap. 4.7.
- Unscrew the knurled screw (38) completely. You can now take the specimen clamp (40) off of the base plate (39) (Fig. 23).
- Attach the rotating stage assembly (42) to the base plate so that the pin (41) fits into the bore (45) provided.
- Then, screw the knurled screw (38) into the thread and tighten it, thus fastening the rotating stage assembly (41) to the base plate (39).
- Install it in the main specimen bath (23) as described in Chap. 4.7 (Fig. 25).

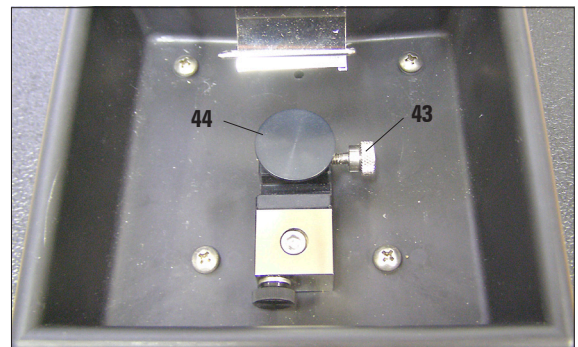

Fig. 25

4. Setup the Instrument

4.8 Assembling the magnifier

The standard scope of delivery of the instrument includes a 2x magnifier that can be assembled on the lamp carrier.

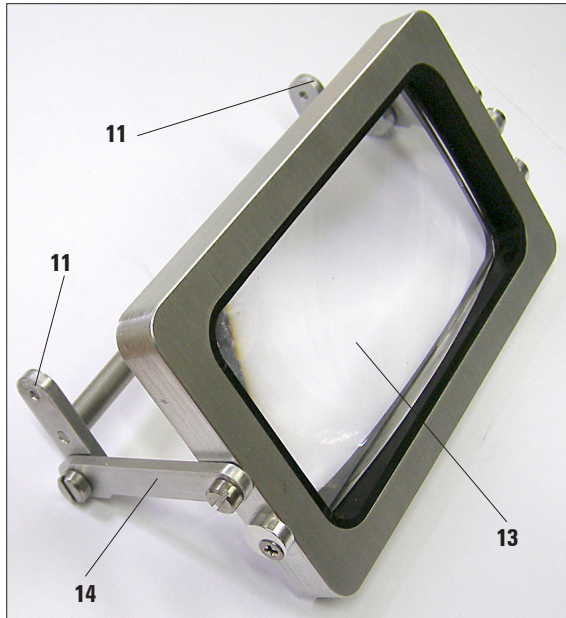

Fig. 26

- For precision viewing of the sectioning process, the magnifier can be moved and adjusted on both arms (14).

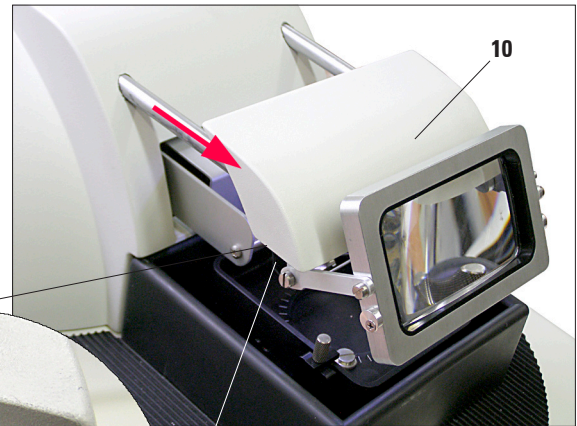
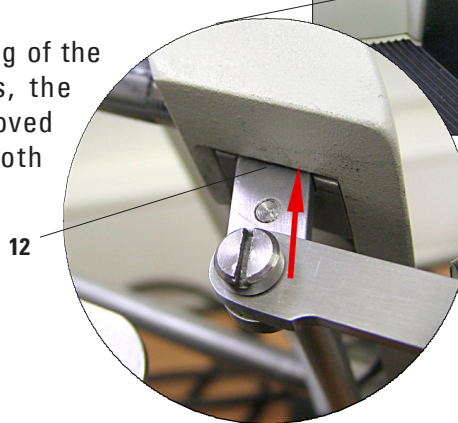

Fig. 27

- Move the lamp carrier (10, in Fig. 27) on the instrument out by pulling it forwards.
- The bottom of the lamp carrier has two notches (12), one each on the left and right.
- Install the magnifier (13) so that the two pins (11) on the left and right fit into the corresponding groove. Push the pins upwards into the groove as far as they will go as shown in the enlarged section of Fig. 27.
- The magnifier is now securely fastened and can be moved along with the lamp carrier.

- To remove the magnifier, follow the reverse order of steps.

5.1 Operating elements and their functions

5.1.1 The control panel

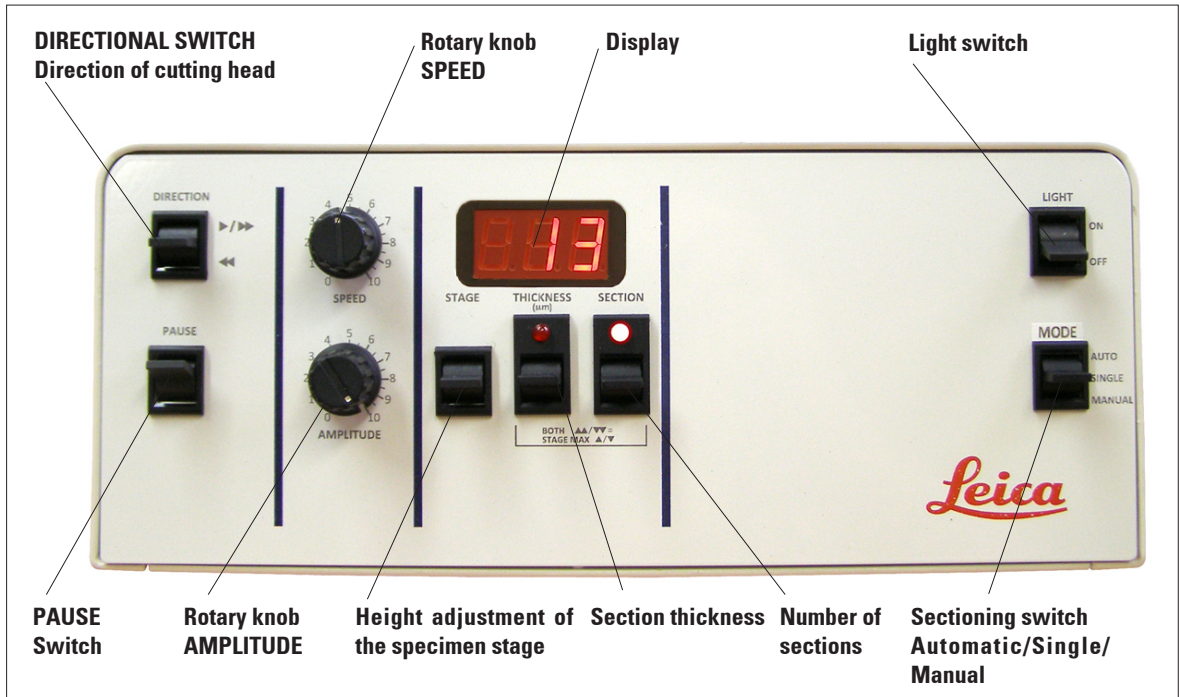

Fig. 28

5.1.2 The operating elements

PAUSE switch



Fig. 29

With this switch, you can temporarily stop the feed movement of the blade at any place.

The **PAUSE** switch is useful particularly if you want to adjust the height of the specimens or remove specimens during a cycle.

Switch position: Upwards → Sectioning is interrupted.

Downwards → Sectioning is possible.

5. Operation

The operating elements (continued)

DIRECTION switch



Fig. 30

Switch position:

Upwards --> forwards

Downwards --> backwards

This switch and its three switch positions (upper, center, lower) control the movement direction of the cutting head.

- Push the switch upwards to start the sectioning cycle. The sectioning blade will advance forward at maximum speed when the switch is held at its top position.
- As soon as the switch is released, it returns to the center position.
- The blade continues the feed movement with the default values for **SPEED** and **AMPLITUDE**.
- At the end of the sectioning window, the movement direction of the blade is reversed and the cutting head moves back. Reversing stops when the rearmost "ready" position is reached.
- During the feed movement, the movement direction can be reversed at any time by moving the switch to the lower position.
- Likewise, during the retraction movement, you can switch direction by pushing the switch upwards.

Rotary knob SPEED

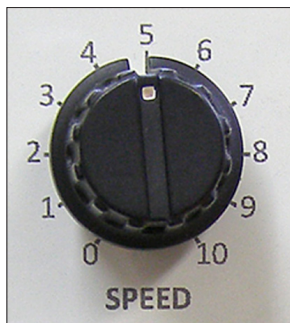

Fig. 31

Using this rotary knob, you can change the relative speed of the cutting head (feed movement) if the **DIRECTION** switch is in the **FWD/AUTO REV** position.

- In the zero position ('0'), the blade does not move; in the '10' position, it is moved at maximum speed (2 mm/s).
- For the positions in between, the speed is changed proportionally.



Only the feed rate can be changed; this is also possible during the sectioning process.
The retraction speed is always the same.

The operating elements (continued)

AMPLITUDE rotary knob



Fig. 32

This knob controls the relative amplitude of the lateral excursion of the sectioning blade vibratory movements.

- In the zero position ('0') or during the retraction movement of the cutting head, the blade does not vibrate.
- The maximum amplitude (2.0 mm) is reached when the rotary knob is in the '10' position. At intermediate settings, the amplitude will vary proportionally.



All configured values are active during the feed movement of the cutting head only. The amplitude can also be changed during the sectioning process.

STAGE switch



Fig. 33

Using this switch, you can move the specimen stage with the specimen upwards or downwards quickly.

The movement continues as long as the switch is held in the respective position. When the switch is released (mode switch must be in auto or single position), it springs back into the center position and the movement is interrupted.

Switch position:

Upwards --> Specimen stage moves upwards.

Downwards --> Specimen stage moves downwards.

LED display



Fig. 34

The LED display shows the values defined for section thickness in single mode and the number of sections and section thickness in automatic mode.

- The LED (**53**, **54**) in the **THICKNESS** (section thickness) switch or in the **SECTION** (number of sections) switch is illuminated when the corresponding parameter is being displayed (see [Fig. 37](#)).

5. Operation

The operating elements (continued)

THICKNESS switch

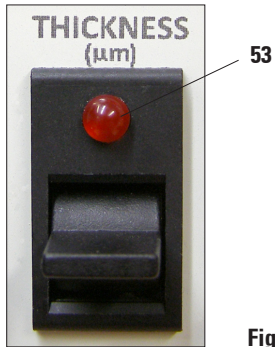

Fig. 35

The **THICKNESS** switch defines the desired section thickness for automatic mode in microns.

- The parameter selected for this value is indicated in the LED display above the switch, the displayed values are specified in μm . The LED (**53**) in the switch is then illuminated.

Switch position:

Upwards --> Values for the section thickness are increased.

Downwards --> Values for the section thickness are decreased.

SECTION switch

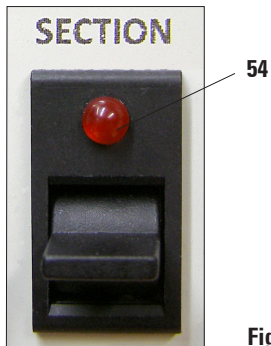

Fig. 36

Using the **SECTION** switch, the number of sections required for automatic mode (**AUTO**) are defined.

- The value selected for this parameter is indicated in the LED display above the switch; the LED (**54**) in the switch is then illuminated.

Switch position:

Upwards --> Number of sections is increased.

Downwards --> Number of sections is decreased.

- If this parameter is set to the value '000' manually, the instrument switches to single sectioning mode until automatic mode is deactivated via the switch.



Fig. 37

Additional control operations available in automatic mode

- After the automatic sectioning process starts, after each section, the LED display shows the number of sections remaining, based on the value defined for the number of sections.
- If both switches, **THICKNESS** and **SECTION**, are pushed upwards or downwards simultaneously, the specimen stage is moved up or down to the maximum or minimum height position. When this position is reached, the LED (**54**) in the **THICKNESS** switch flashes.

The operating elements (continued)

MODE switch

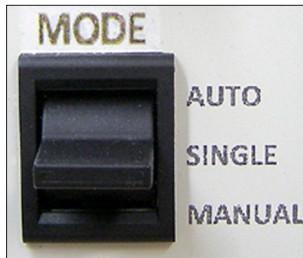

Fig. 38

The **MODE** switch serves to toggle between the manual, single and automatic modes.

Switch position: **MANUAL**

- The instrument works in manual mode only; the LED display is not illuminated. The section thickness must be adjusted using the section thickness setting wheel (Fig. 3).

Switch position: **SINGLE**

- Only one section can be created at a time.
- Using the **THICKNESS** switch, you can adjust the desired section thickness; the value is shown in the LED display.
- The user must press up on the directional switch to start another section. The instrument will retain the desired section thickness.

Switch position: **AUTO**

- Using this switch position, you can activate the automatic sectioning mode of the instrument. In automatic sectioning mode, the operator can set the desired section thickness and number of sections. The Vibratome carries out the task automatically. This is a great benefit for serial sectioning.
- The desired section thickness can be configured using the **THICKNESS** switch and the number of sections can be configured using the **SECTION** switch. The respective value appears in the display.



The automatic switch also serves as the reset button in automatic mode. If you want to reset the instrument in serial sectioning mode to the default parameters for sectioning operations and section thicknesses, the counters can be reset using the automatic switch.

LIGHT switch



Fig. 39

This simple switch switches on the fluorescent lamp and thus improves the illumination of the specimen tray. Switch position:

ON --> Light is on.

OFF --> Light is off.

5. Operation

5.2 Adjustment options on the instrument

5.2.1 Adjusting the blade presentation angle

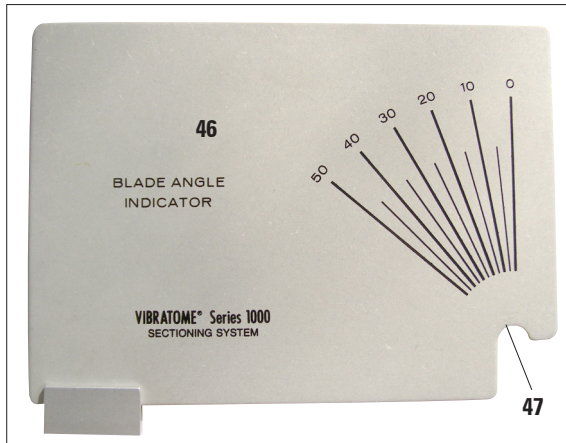

Fig. 40

**Enlarged detail:
Scale of the blade angle
indicator and indicator
on the blade holder.**

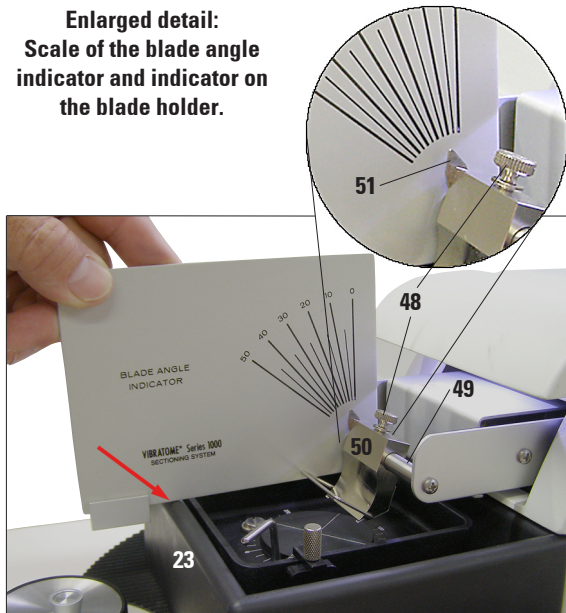

Fig. 41

The presentation angle of the sectioning blade relative to the plane of the section is adjustable to suit operating conditions and specimen types.

The adjustment can be made by rotating the blade holder (50) on the mounting bar.

- The accessories include a blade angle indicator (46) for this purpose.
- To read the blade angle using this indicator, hold the angle indicator against the left side of the blade holder. The notch (47) must be touching the mounting bar (49) of the blade holder (50) and the lower edge must be touching the specimen tray. (Fig. 40/41).
- For the adjustment, first unscrew the knurled screw (48) on the blade holder with a screw driver. (Fig. 41).
- During the adjustment, it is important that the bottom edge of the blade angle indicator is touching the main specimen bath. (23) (arrow in Fig. 41). For this purpose, it may be necessary to move the cutting head forward.
- Now, rotate the blade holder until the small indicator (51) specifies the desired value on the scale of the blade angle indicator.
- Retighten the knurled screw so that it cannot come loose during sectioning.
- For additional information about adjusting the blade holder, refer to the following section.

5.2.2 Adjusting the specimen and blade

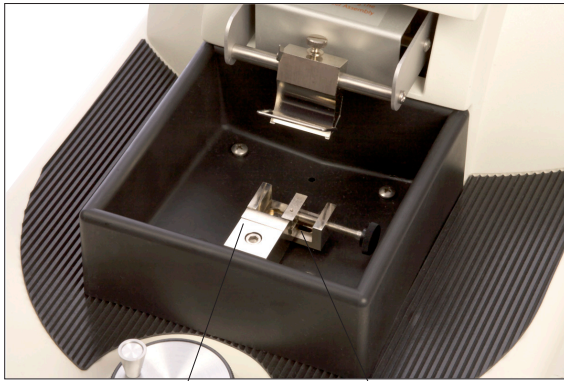

Fig. 42

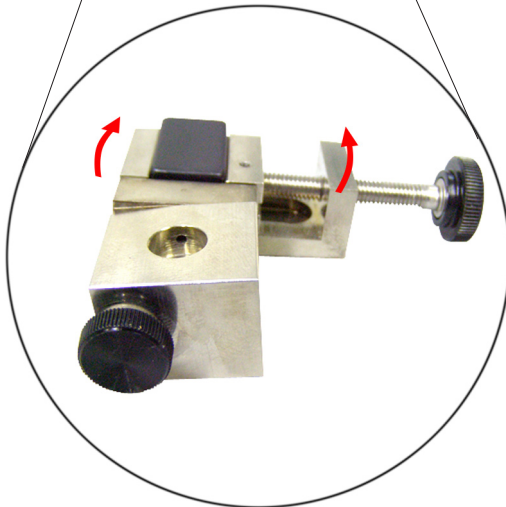

Fig. 43

Positioning the specimen in the specimen holder

You can adjust the lateral position of the specimen in order to attain an approximate centering of the specimen in the specimen tray. Since one of the jaws of the specimen holder is stationary, the use of specimen mounting blocks of varying widths will allow for adjustable specimen mounting.

Adjust the tilt of the specimen holder.

You can adjust the tilt of the specimen holder in one axis in order to make the specimen surface approximately horizontal.

- To do so, first unscrew the locking screw with a plastic head between the front side of the holder and the wall of the specimen tray.
- You can now tilt the entire specimen holder to one side.

5. Operation

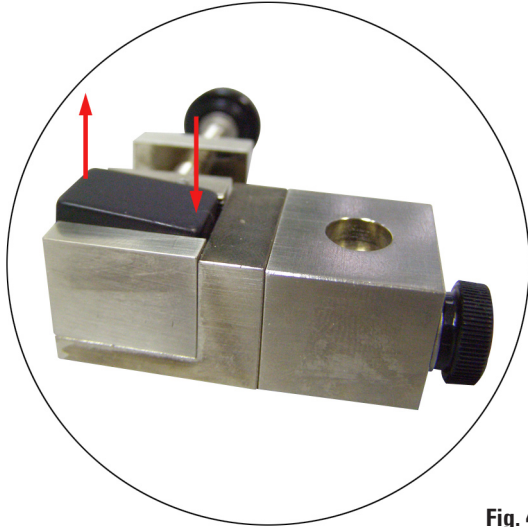

Fig. 44

Adjusting the tilt of the specimen

If the specimen is still not completely horizontal, you can tilt the specimen along another axis (from side to side).

To do so, tilt the specimen mounting block slightly when it is clamped in the jaws of the specimen holder.



Complete control of the specimen over all three axes is possible with the rotating stage assembly (see Chap. 7.2, Optional Accessories).

Moving the blade holder relative to the specimen

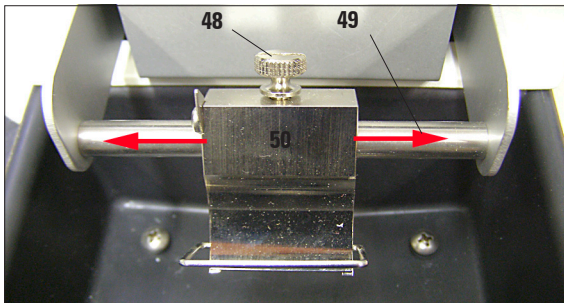

Fig. 45



Because the knurled screw (48) is also used to adjust the blade presentation angle, the angle may have changed. Therefore, recheck the blade angle after this adjustment.

In some cases, e.g. for large specimens, it is necessary to move the blade holder (50) on the mounting bar.

When the width of a large specimen is approximately the same as the sectioning blade edge length, the lateral positioning of the sectioning blade may have to be adjusted to ensure complete sections.

- By loosening the knurled screw (48), you can move the blade holder sideways along its axis (49) and thus position it more accurately relative to the specimen (Fig. 45).

5.2.3 Adjustable sectioning window

The VT1000 A features an adjustable sectioning window that you can use to speed up the process of making series sections.

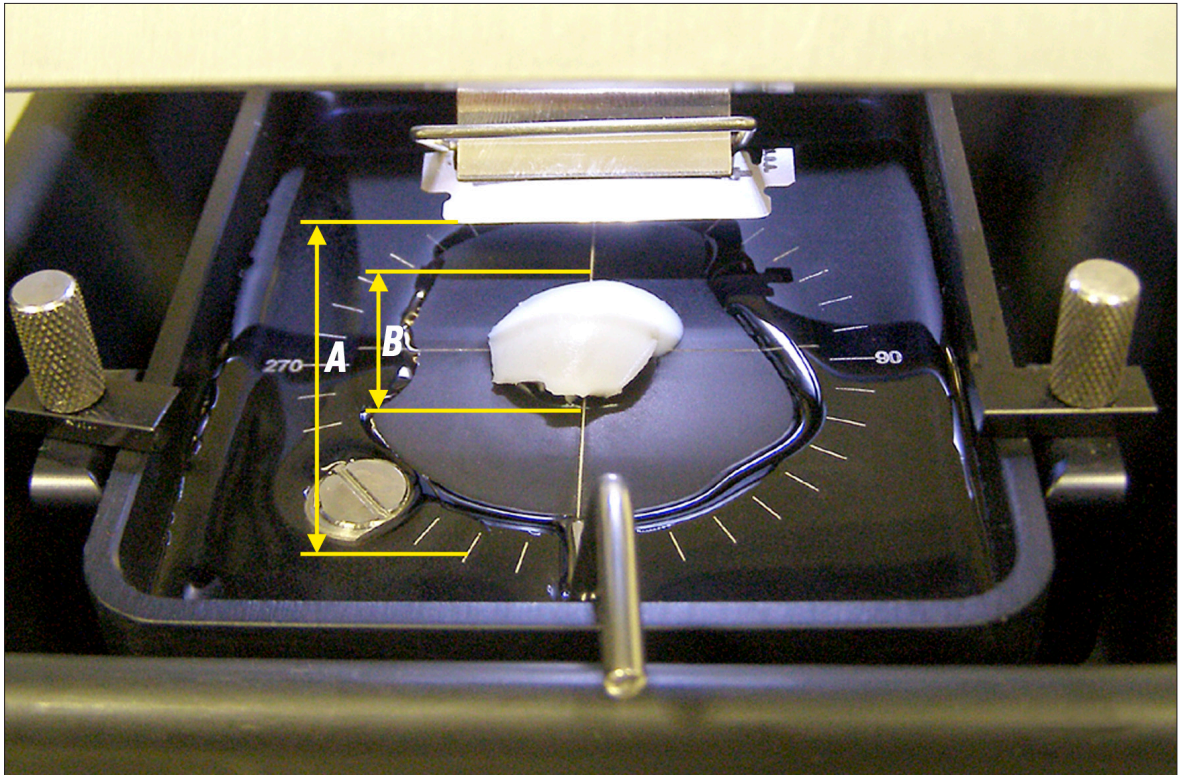

Fig. 46

This "window" is the distance the blade travels from a resting retracted position to the front of the bath when it automatically ends the forward stroke and reverses.

This corresponds to distance "A" in Fig. 46.

If the front and rear edge of the "window" are positioned as close as possible to the front and rear end of the specimen, it is only necessary to cover distance "B" for a section.

This reduces the time for a complete cycle or section significantly.

5. Operation

Adjustable sectioning window (continued)

To make this adjustment, the instrument should be in manual mode.

To adjust the front and rear edge of the sectioning window, you have to move the internal limit switch using two rotary knobs (57), which are on the side of the top plastic cover of the Vibratome. The two rotary knobs can be adjusted independently of one another.

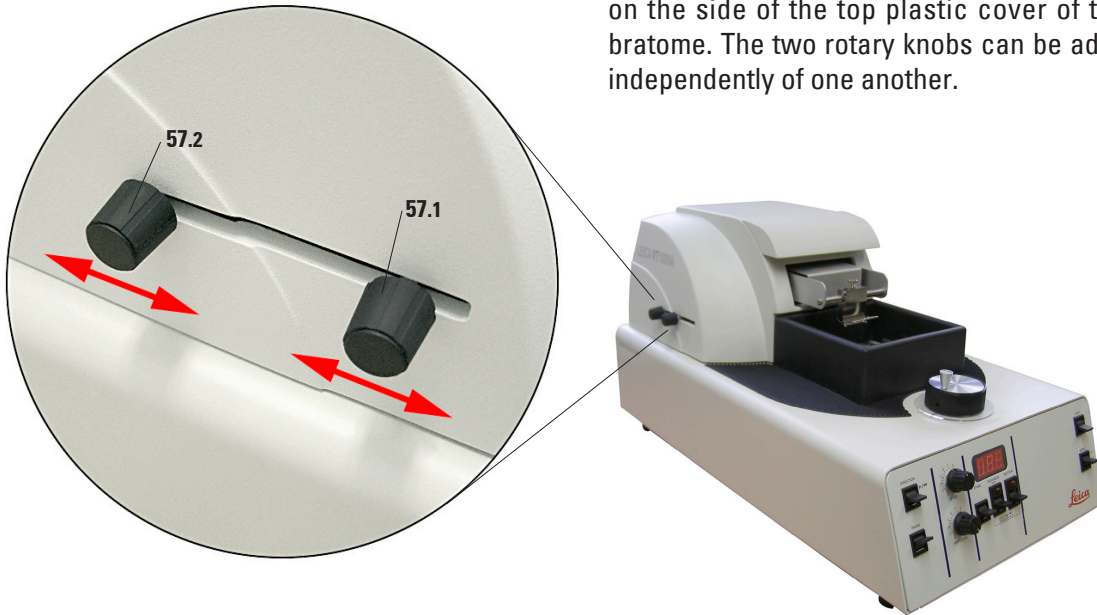

Fig. 47

- First, adjust the front limit switch that is on the front side of the instrument.
- To do so, release the knob (57.1) with the blade fully retracted and move it into the desired position.
- As soon as the switch is in the desired position, tighten the knob again so that it cannot be disengaged during sectioning.
- The rear switch can be moved only while the instrument is in operation.
- To adjust the rear limit switch, turn the knob (57.2) counterclockwise to disengage the switch.
- Then, start the sectioning operation using the switch for the feed movement of the Vibratome.
- During the feed movement of the blade, push the switch forward until it reaches the desired position.
- Finally, tighten the knob to fix the switch in place.
- You can readjust the sectioning window whenever new specimen sizes are used.

5.2.4 Adjusting the specimen height

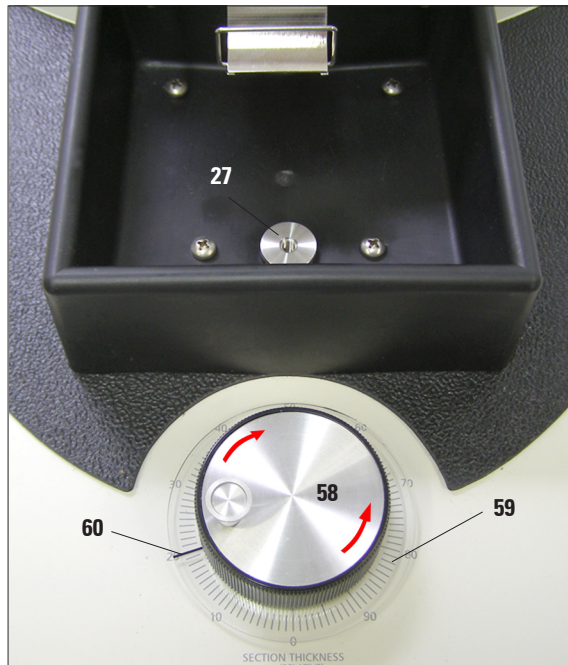

Fig. 48

The thickness of sections generated is controlled by the raising of the specimen incrementally. Since the sectioning blade remains stationary along the vertical axis, the increment by which the specimen is raised correlates to the section thickness.

The height of the specimen is adjusted using a micrometer feed system that is located below the specimen tray.

The rotational movement of the setting wheel (58) for the section thickness is converted into a vertical movement by the micrometer feed system.

Turning the wheel clockwise raises the specimen stage (27) on which the specimen holder is fastened, while turning it counterclockwise lowers it.

When turned, you can feel the setting wheel engage in notch increments of 5 μm .

The scale (59) is divided into μm increments (10^{-6} meter), where the scale values are selected randomly, i.e. it is not important where the black pointer (60) of the scaled adjusting knob is. To create a section with a thickness of 60 μm , the setting must be increased by 60 scale increments.



Important!

The respective setting is always consistent in one direction of rotation only.

Example:

If the setting wheel has been turned clockwise to the setting "30", then turned back counterclockwise to "25" immediately afterwards, this does not lower the specimen by 5 μm . To actually lower the specimen by 5 μm , you have to turn the wheel approx. one quarter turn counterclockwise PAST the setting "25", then back to "25" again.

This means that to compensate for the small amount of play in the micrometer feed system, before each adjustment in the direction opposite to the last one, you first have to turn the setting wheel one-quarter turn past the new value. Only then can you make the desired adjustment.

5. Operation

5.3 Sectioning

The Leica VT1000 A offers a wide variety of options for sectioning fixed and unfixed tissue samples of plant or animal origin. It employs a vibrating blade principle, which allows sectioning without freezing or embedding. This makes it possible to prevent the unwanted effects that occur during freezing or embedding, such as the formation of artifacts, change of the morphology, the impairment of enzyme activities and other harmful processes.

The patented vibrating blade principle moves the sectioning blade edge in a reciprocating arcuate path as it penetrates the specimen. The reduced effective edge angle from the transverse movements, together with the lateral distribution of the cutting edge penetrating pressure, minimize elastic deformation of soft tissue specimens that are simply held or encapsulated in position during the sectioning operation. Uniform sections, as such, can be made of delicate soft tissue specimens. Sections made are free of observable compressive distortion in the direction of cut, as would be typical with conventional microtomes. Because the tissue cells on the surface of the sections are not damaged, the ultrastructure in the sections is also kept intact.

The sectioning process takes place in a specimen bath. The liquid serves as a lubricant for the blade; it also keeps the specimen temperature constant and maintains or reinforces the desired features of the specimens. It also serves to facilitate the easy retrieval of the sections from the bath.

The instrument works semi-automatically; this means that the operator only has to initiate the sectioning operation. After finishing a section, the instrument remains in standby mode until the section is removed or another sectioning operation is started. The amplitude of the blade vibration as well as the feed rate and presentation angle of the blade can be adjusted individually by the operator, making it possible to attain optimum results for a wide variety of specimens.

There are essentially three operating states for the Electronics Assembly:

- A. Sectioning blade advancing FORWARD with vibratory movement ON.
- B. RETRACTION of the blade with vibratory movement OFF.
- C. Sectioning blade in a rearmost "READY" position with vibratory movement OFF.

Sectioning (continued)

When the instrument is switched on for the first time, the blade is automatically moved back in operating state "B" and stopped in state "C".

Each sectioning cycle needs only to be initiated by the operator. Once state "A" is activated, the sectioning blade will advance at the operator-selected forward speed and amplitude until it reaches the forward end-of-travel. The blade then switches into operating state "B" automatically until state "C" is reached. It will then remain in state "C" until another cycle is activated by the operator.

When in state "A", a momentary override of the preselected forward speed is available. In this way, you can select the maximum feed rate for the movement between the rearmost "ready" position and the specimen.

The retraction movement of the blade in operating state "B" always takes place at the maximum speed, regardless of the preset feed rate.

At any time during the sectioning cycle, operator override of the semi-automatic operation is available. Thus during feed in operating state "A", the blade can be moved back in state "B" and vice versa.

5. Operation

5.3.1 General instructions

As a result of the great variety of specimen types, sizes, shapes, states and preparations, etc. that can be encountered while sectioning with the VT1000 A, it is not possible to provide specific recommendations for parameter settings. The optimal settings for the individual applications can be determined only empirically using specimens that are no longer needed and are as similar as possible to the actual specimens to be sectioned.

The most important function of the instrument is producing tissue sections without prior freezing or embedding. This is made possible by a lateral movement of the blade while it penetrates the specimen. Therefore, the ratio between the lateral speed (which is proportional to the amplitude adjustment) and the feed rate is one of the central parameters for attaining high-quality sections for the widest variety of specimen types.

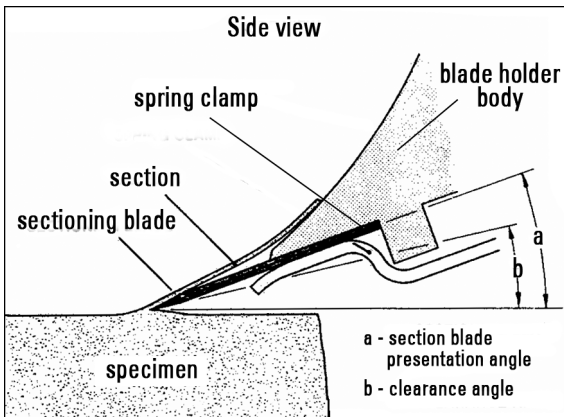

Fig. 49

Generally, solid specimens can be sectioned with a small ratio of amplitude to feed rate (i.e. a high feed rate).

For soft specimens, on the other hand, we recommend a large ratio of amplitude to feed rate (i.e. a large amplitude).

If the section breaks up due to excessive agitation, the amplitude setting should be reduced.

In normal sectioning, the specimen is lifted upwards elastically as the blade advances. This is illustrated in Fig. 49.

A small clearance angle to the specimen will exist when the blade reverses after a section. This lifting phenomenon varies with parameter settings and is more pronounced with softer specimens, higher advance speeds, higher blade presentation angles, and particularly with thicker sections being generated.

In general, it does not materially affect the section performance provided that parameter settings are not changed during a section and gradual transitions are made in section thickness changes (especially going from thick sections to thin sections) during serial sectioning.

5.3.2 Inserting the specimens

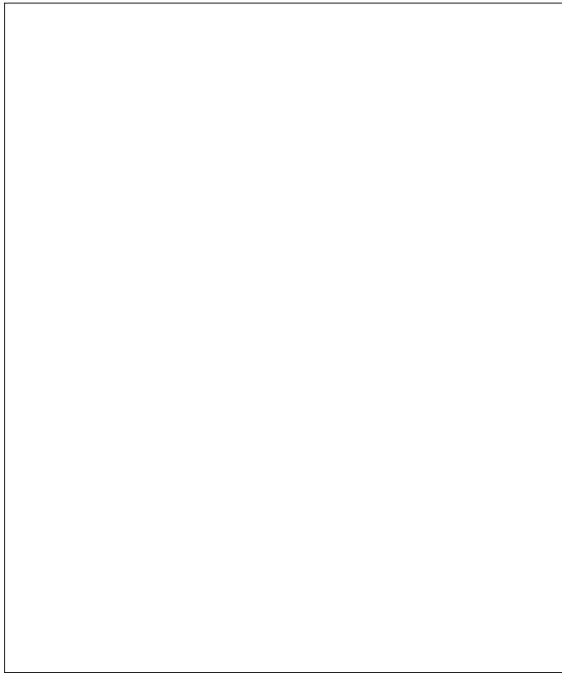

Fig. 50

Direct mounting

Specimens rigid enough to be held firmly in the specimen holder without damage may be clamped directly.

Keep in mind that excessive clamping forces on the jaws of the specimen holder can cause tension in the specimen.

Softer specimens that do not have enough strength on their own (such as a leaf) can be placed between carrier strips or two layers of soft material, e.g. balsa wood or low melt agarose, then inserted into the specimen holder.

The supporting material should cut easily and may be separated from the tissue section in the bath area after sectioning.

To ensure sufficient strength, the specimen should, where possible, be clamped in the holding jaws directly or with the least amount of inlay material possible.

Adhesive mounting

Fragile specimens that are difficult to align correctly can be adhered directly or indirectly to the specimen mounting blocks, which are included in the accessories.

Use only the cyanoacrylate adhesive provided for adhering the specimens. Using this adhesive, the widest variety of materials (e.g. unfixed liver tissue, heart tissue, fixed brain and kidney tissue or fragile plant specimens) can be fixed on a specimen holder quickly and reliably.

For specimens that are insufficiently rigid in unfixed condition for adhesive mounting, prior fixation may be performed if not detrimental to the phenomenon or process for which specimens are being studied.

Alternately, the specimens may be encapsulated in a support medium such as agar or gelatin. The block of support medium, together with the specimen, may be trimmed to size and adhesive mounted upon solidification.

5. Operation

Adhesive Mounting (continued)

Note that in all cases requiring adhesive mounting, thickness of the specimen should be kept as small as practical to maximize rigidity.

Before sectioning with the VT1000 A, create a uniform, level surface along the cutting edge of the tissue; this will reduce the time needed for cutting the specimen to size using the blade.



Be very careful when using the adhesive, as it very easily sticks to human skin. Avoid direct skin contact with the adhesive under any circumstances.

If, despite this, you come into direct contact with the cyanoacrylate adhesive provided, first allow the adhesive to air dry, then wipe it off with a towel soaked in acetone. When unintentional bonding of skin occurs, separate by a "peeling" (rather than pulling) action after applying acetone to bond area.

Instructions for a clean bond

The surfaces onto which the specimens are attached must be clean, dry and free of adhesive residue from previous applications.

The specimen mounting blocks specimen tray, and deluxe specimen bath have a hard surface coating that should not be impaired, even by repeated sectioning operations with razor blades.

- Carefully wipe the surface of the specimens to be attached using absorbent paper to remove fluid residue that could impair the adhesion.
- Apply a sufficient quantity of adhesive to the contact surface so that the entire specimen is fixed.
- Experience has shown that most deviations in the quality of the sections is due to partial detachment of the specimens.
- Because the adhesive effect sets in very quickly, the specimen should be applied to the adhesive surface carefully and accurately the first time.
- If the specimen permits, carefully press on it to increase the adhesive effect.

Adhesive Mounting (continued)

Specimens small enough to fit on a surface of a specimen mounting block can be affixed directly.

The specimen mounting block is then clamped into the jaws of the specimen holder for sectioning.

If the specimen requires a larger surface, you can use specimen tray (39053744) or the deluxe specimen bath (39053745).

Fig. 51

For specimens that are insufficiently rigid in unfixed condition for adhesive mounting, prior fixation may be performed if not detrimental to the phenomenon or process for which specimens are being studied. Alternately, the specimens may be encapsulated in a support medium such as agar, gelatin, or paraffin. The block of support medium, together with the specimen, may be trimmed to size and adhesive mounted upon solidification.

Note that in all cases requiring adhesive mounting, thickness of the specimen should be kept as small as practical to maximize rigidity. Create a uniform, level surface with a cursory manual processing; this will reduce the time needed for cutting the specimen to size using the blade.

5.3.3 Selecting and inserting the blade

Depending on the type of specimens sectioned, the type and brand of blades may affect the instrument performance.

Before either type of blade is used for sections, it must be cleansed thoroughly of oil or silicone residue. To do so, we recommend placing the blade in a xylene bath for approximately 10 minutes, then flushing it with acetone and allowing it to air dry.

5. Operation

Inserting the blade

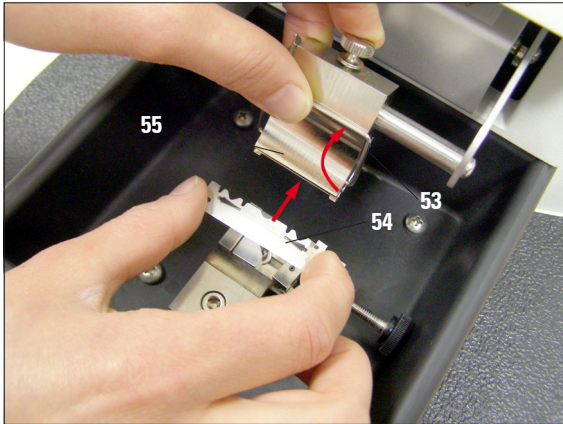

Fig. 52

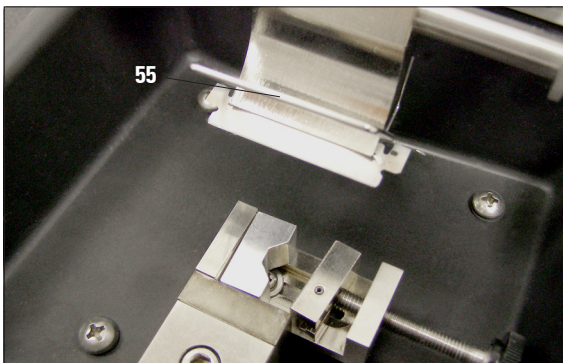

Fig. 53



Be careful when handling the disposable blades or sapphire knife. The cutting edge is extremely sharp and can cause serious injuries. Before inserting a blade, the specimen to be sectioned should be attached to the specimen plate (clamped into place or affixed) to prevent injuries.

The blade is held in place by a spring clip (53) in the blade holder that presses against the bottom of the blade holder.

- First, push the spring clip (53) upwards using your left thumb (Fig. 52).
- To insert the blade, hold it (54) by its dull ends using your thumb and index finger and insert it into the blade holder (55) (Fig. 43), then carefully release the spring clip - Fig. 44 shows the correctly inserted blade.



For high-quality sections, a sapphire knife is available (39 053237). This knife fits in the standard blade holder and provides a superior means for sectioning tissue. When handling the blades, exercise particular caution to ensure that the blade edge does not contact any object. Resulting microscopic damage to the blade edge may cause localized tearing of the specimen. Caution must also be exercised when handling the blades to prevent operator injury from accidental cuts.

5.4 Specimen preparation

Prior to sectioning, gross trimming of the specimen top surface with the sectioning blade to achieve flatness is required.

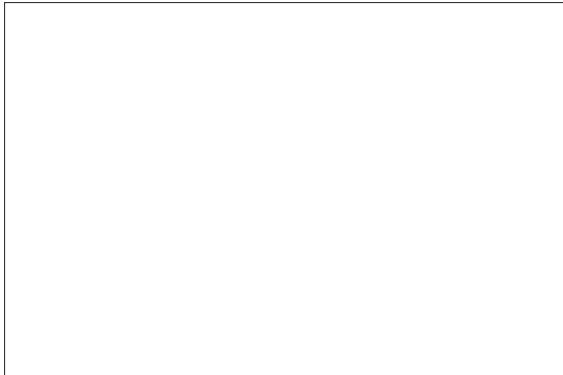

After the specimen and mounting block have been clamped into the specimen holder in the desired orientation relative to the blade feed direction, the top surface of the specimen should be kept approximately horizontal.

Two means of adjustment are available: the tilt of the specimen holder and the tilt of the specimen mounting block within the specimen holder jaws.

Fig. 54

The speed and amplitude should be set to "0" initially. Then, advance the blade until it almost touches the specimen.

For this purpose, briefly push the direction switch upwards. With the sectioning blade close to the specimen, their relative heights may be gauged approximately. The specimen should then be raised (or lowered) to a position just below the blade edge.

The specimen may then be trimmed by serial sectioning until complete sections can be made of the area of interest on the specimen. With unfamiliar specimens, to minimize the chance of specimen damage, the advance speed should be at a low setting while the amplitude should be at a medium setting. The section thickness should be increased at suggested intervals of 50 μm .

If the specimen permits, the speed and section thickness may be gradually increased to reduce trimming time. However, be careful so that the specimen does not twist or fall out of the specimen holder.

5.5 Preparing the specimen bath

The purpose of the specimen bath is four-fold: to lubricate the blade during the sectioning operation, to prevent the specimen from heating up or drying out, to increase or maintain desired features of the specimen and to allow effortless removal of the fragile sections.

Any fluid, compatible with polypropylene and nitrile rubber, that would best preserve or maintain the phenomenon or process for which the specimen is being studied may be used. A wide variety of fluids have been used successfully ranging from a balanced saline solution, buffered phosphate solutions, alcohols, hydrocarbon, distilled or deionized water, glycerols, mineral oils and formalin.

The fluid chosen should not cause the rapid swelling of the specimen. In case such a fluid must be used, the specimen should be allowed to swell in the fluid before being mounted in the specimen holder. Normal saline solution is recommended for unfixed animal tissue. Distilled or deionized water may be used for fixed animal tissues and botanical specimens. Caution must be exercised when using toxic or inflammable fluids, as they may pose a risk of injury to the operator.

Any bath fluid may be externally cooled (or heated) to achieve maximum sectioning consistency or to preserve enzymatic activity. In most applications, the specimen bath is maintained at just above freezing using the immersion probe of a separate cooling unit. For information on possible sources of supply, refer to the section entitled "Accessories". Alternately, if the specimen bath is aqueous, ice can be added.

After setting the desired blade presentation angle, fill the bath until the blade edge is about 3 to 4 mm below the surface. At this fill level, the section will either lie directly on the bent front of the blade holder or float directly in front of the blade.

5.6 Conventional sectioning

After the specimen has been trimmed to create a flat specimen surface, the preparations for actual sectioning can be carried out. The procedure consists of generating a few sections at the final parameter settings and section thickness. This is intended to compensate for the effect of lifting the specimen described in the section entitled "General instructions". This effect can be observed in that the first, and possibly the next few, sections will be either nonexistent or too thin. Later, when changing from thick sections to much thinner sections, the procedure should be repeated.

As soon as the optimal parameter settings have been determined according to the procedure recommended in the "General instructions" section, the sectioning operation can be carried out with these settings. Note that while a section is being generated, the parameter settings must not be varied, otherwise the thickness may also vary within the section. Note also that the section thickness may be increased (by turning in the clockwise direction) only after the sectioning blade has passed the specimen while reversing. If the rotary knob for section thickness is turned counter-clockwise, a subsequent compensation for the inner play is required (see the section on "Adjusting the height of the specimens").

Because the instrument operation is semi-automatic, the operator only has to initiate each sectioning cycle. The instrument will then complete the section, unattended if desired, and return to the rearmost "ready" position. With an increase in the speed setting, the blade can be moved quickly from the "ready" position towards the specimen. In this case, a sufficient "braking distance" should be provided to slow down the blade to the preset feed rate before it touches the specimen.

The lamp/magnifier assembly may be used to facilitate close observation of the specimen during sectioning.

5. Operation

5.7 Removing the sections

Sections generated may be retrieved from the specimen bath by various means.

For microscopic applications, the section may be delivered to a glass slide by aspirating the section with a small glass dropper if doing so does not damage the specimen.

In some cases, using a fine sable brush provides more satisfactory results, since the risk of section damage is reduced.

In other cases, the section can be transferred to another specimen bath and picked up there using a partially submerged glass specimen slide.

The sable brush or a blunt glass rod may be used to manipulate the section while it is in the specimen bath.

Once the section is positioned properly on the glass specimen slide, it may be adhered with albumin or other mounting media.

Staining or other treatment, then coverslipping, may be carried out as for a typical conventional section for microscopy.

After you have obtained all the sections you need, the entire area of the specimen tray should be cleaned (refer to Chapter 6, "[Cleaning](#)").

6.1 Cleaning the instrument



- Always remove the blade before detaching the blade holder from the instrument!
- Always keep the sapphire blades in the box when not in use!
- Never place used blades on the laboratory table - dispose of them safely!
- When using detergents, comply with the safety instructions of the manufacturer and observe the laboratory regulations valid in the country of use.
- When cleaning the outer surfaces, do not use xylene, scouring powders or solvents containing acetone or xylene. The finished surfaces are not resistant to xylene or acetone!
- Ensure that no liquids enter the interior of the instrument when cleaning!

Before each cleaning, carry out the following preparatory steps:

- Move the specimen vice assembly into the lower end position.
- Remove the blade from the blade holder and dispose of it safely (before disposing of used blades, apply thick "Scotch" tape to the cutting edge or wrap the entire blade in paper) or place the sapphire blade in the knife case.
- Remove the specimen from the specimen vice assembly.
- Remove section waste and dispose of it safely.
- Remove specimen vice assembly and clean separately.



- Do not open any covers or casing panels of the instrument, as electrically live parts are on the inside!

6. Cleaning and Maintenance

Specimen bath area

After sectioning is completed, the specimen bath, specimen holder and sectioning blade holder should be cleansed of any bath solution residue. Any water-soluble solvent may be used unless it corrodes parts made of polypropylene or nitrile rubber. The final flushes should be with clean water.

This procedure is intended to premature corrosion of metal components in this area, buildup of substances or contamination of subsequent baths.

Magnifier lens

The lens in the lamp and magnifier module should be cleaned if possible using a soft cloth soaked in ethanol or conventional glass cleaner. A final buffing with clean dry tissue should follow.

Cleaning the instrument and outer surfaces

Any liquids spilled on the instrument should be wiped off immediately.

- If necessary, the varnished outside surfaces can be cleaned with a mild (nonabrasive) commercial household cleaner or soapy water and then be wiped with a moist cloth.
- The instrument must be completely dry before it can be used again.
- Anodized parts (e.g. the specimen clamps) can also be cleaned with solvents.

A vinyl instrument cover is provided in the accessory package for protection against dust or scratching between use.

6.2 Maintenance instructions



Only authorized, qualified Leica service personnel may access the internal components of the instrument for service or repair!

When used normally, the Vibratome VT1000 A requires only standard maintenance.

To ensure trouble-free operation of the instrument over a long period of time, the following is recommended by Leica:

- Thoroughly clean the instrument on a daily basis.
- From time to time, oil the specimen holder (see [Fig. 4, Page 9](#)), blade holder and specimen clamp (e.g. after cleaning in the sterilization oven or using solvents).
- Have the instrument inspected according to the maintenance contract by a qualified service engineer authorized by Leica.
The intervals depend on how heavily the instrument is used.



All service repairs covered under the Warranty Policy shall be performed at no expense to the user.

In case of a complete failure of the instrument, follow this procedure:

- First check the power supply on the power socket.
- Then, check the fuse(s) on the rear side of the instrument - see [Chapter 6.3](#) "Replacing components". For this purpose, it is mandatory to disconnect the power cable from the power supply.
- If a fuse is defective, you must have identified and corrected the cause of the burned-out fuse before plugging the power cable back in. If no fuse is defective, please contact Leica service.

6. Cleaning and Maintenance

6.3 Replacing components

6.3.1 Fuse

If the instrument fails to function completely, first check for power availability at the power outlet. The instrument fuse(s) located at the rear of the instrument should be checked next. Before removing the fuse, pull the **POWER PLUG OUT OF THE SOCKET**. The fuse and its holder are removed by lifting the tab in the fuse drawer that is located directly above the plug and pulling the drawer out of the socket.

Check to see if the filament within the glass tube of the fuse is intact. If not, replace with fuse referenced below, two of which are supplied in the accessory package. Before reconnecting the power cord, check the instrument for any obvious cause of the burnt fuse and make the appropriate correction.

Model #	Qty	Fuse
VT1000 A, 110V	1	39GMA-2A
VT1000 A, 220V	2	39F-1A

6.3.2 LED light

If the LED light fails to turn on or flickers when operating, replacement is necessary. The LED light is located under the lamp assembly housing, directly behind the glass magnifier.



BE ABSOLUTELY CERTAIN TO UNPLUG THE POWER CABLE before removing the lamp.

The lamp can be removed from its mounting sockets by first removing the end cap of the lamp housing opposite to the socket. Once the socket is removed, the lamp tube can be removed by pulling the lamp straight out of the socket.

7.1 Ordering information

Specimen mounting block, 3 per package	39053747
Specimen adhesive	39053986
LED light	39053226
Feather Blades, 10 per package	39053234
Specimen Tray	39053744
V-block adapter	39053750
Specimen holder, 1/2 head	39053753
Rotary table module (ball and socket)	39053760
Replaceable rotating mounts	39053763
Sapphire knife	39053237
Specimen Retrievers.....	39053220
Section Mounting Device.....	39053225
Foot Pedal	39053300A